

SIK - Datasheet

In this Datasheet you find information about our Torque-Limiter-Coupling (SIK).

The VMA Torque-Limiter-Couplings type SIK disconnect the drive from the machine quickly, safely and precisely. SIK couplings can be mounted and dismantled in seconds due to a patented fitting system (SSE Quick-Clamping-Units).

It is even more Important to prevent breakdowns caused by a programming or operating errors. In case of collisions a very high rotational or translational kinetic energy is transformed into a deforming energy and in consequence the impact of the damage can be tremendous.



SIK - Datasheet

The torque transmission is both backlash-free and torsion stiff. The indexing disc presses the asymmetrically arranged balls into the spherical ball seats using the adjusted spring tension. Durability is achieved not only by the asymmetrical distribution of the ball seats but also through the asymmetrically slotted ball seats themselves. The external dimensions and construction of the Quick-Clamping-Unit SSE allows the torque limit to be achieved in restricted minimal space applications.

In case of overload, the hub (e.g. shaft) turns against the external ring (e.g. pulley), disengaging the balls from the ball seats. The unit is separated for one rotation and will resume its function after 360°, returning to the same point (constant point



SIK - Datasheet

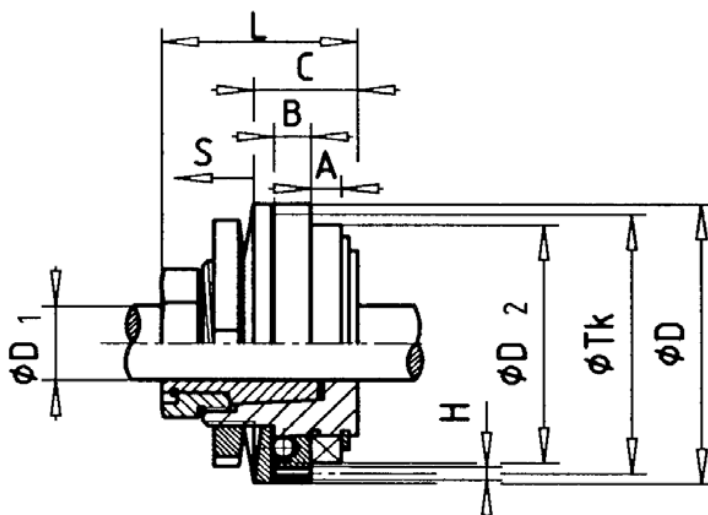

Torque-Limiter-Coupling - SIK

Size		005	010	020	035	050	070	115	170	300	600
L	in mm	40	40	47	51	51	61	61	61	80	80
TK	in mm	55	55	63	72	72	95	95	95	134	134
A	in mm	7	7	7	7	7	10	10	10	22	22
B	in mm	7,4	7,4	8,7	11	11	11,5	11,5	11,5	13	13
C	in mm	21,5	21,5	22,5	27,5	27,5	38,5	38,5	38,5	54,5	54,5
H		M4	M4	M4	M5	M5	M6	M6	M6	M6	M6
S	in mm	1	1	1,2	1,5	1,5	1,8	1,8	1,8	2,2	2,2
D	in mm	62	62	69	79	79	106	106	106	142	142
D1 ISO system of fitting H7	in mm	6-15	6-15	12-20	15-25	15-25	20-40	20-40	20-40	30-50	30-50
D2 bearing one row		61807	61807	61809	61810	61810	61815	61813	61813	6016	6016
Installation wrench		DIN 3110					DIN 1810				

SIK - Datasheet

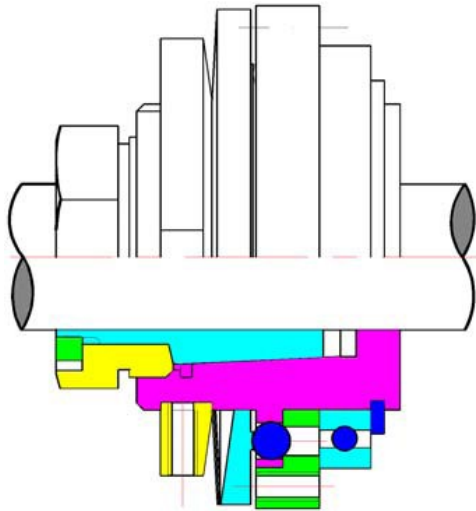

Torque-Limiter-Coupling - SIK

Technical Data

Size		005	010	020	035	050	070	115	170	300	600
Disengagement torque	in Nm	2,5-5	5-10	10-20	18-35	25-50	35-70	55-115	90-170	150-300	300-600
Mass (ca.)	in Kg	0,4	0,4	0,7	1,1	1,1	1,8	1,8	1,8	5	5
Moment of inertia	in 10 ⁻⁶ kg*m ²	0,2	0,2	0,4	0,8	0,8	3	3	5,4	13,7	13,7

Material:

Hardened steel

SIK - Datasheet

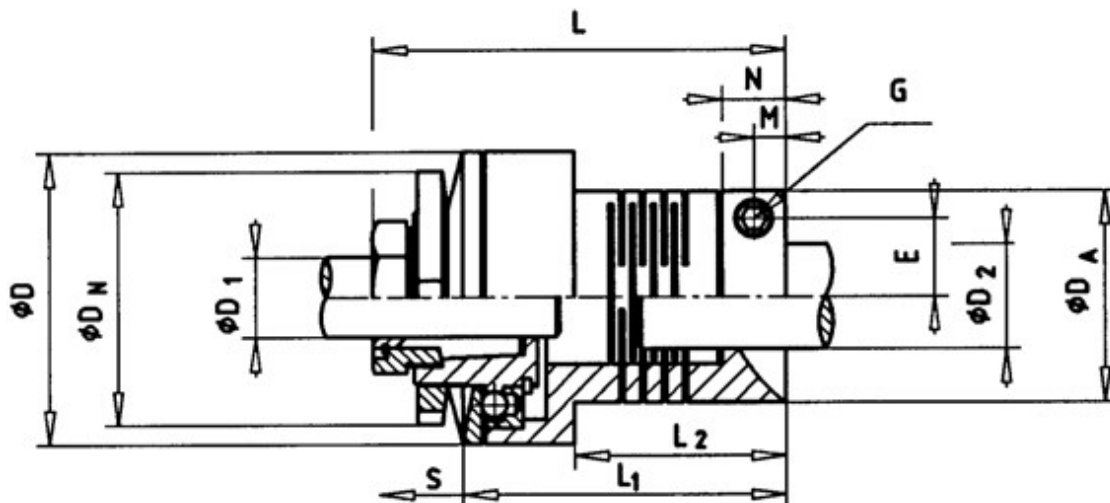

Torque-Limiter-Coupling - SIK

Size SIK		005	010	020	035	050	070	115	170	300	600
Size ASK		040	040	050	050	060	080	080	080	100	100
D	in mm	62	62	69	79	79	106	106	106	142	142
DA	in mm	40	40	50	50	60	80	80	80	100	100
DN	in mm	55	55	60	65	65	85	85	85	120	120
DI	in mm	6-15	6-15	6-20	6-25	6-25	15-40	15-40	15-40	30-50	30-50
D2	in mm	10-19	10-19	15-26	15-26	18-30	25-42	25-42	25-42	30-55	30-55
E	in mm	14	14	18,5	18,5	24	29	29	29	37	37
S	in mm	1	1	1,2	1,5	1,5	1,8	1,8	1,8	2,2	2,2
L	in mm	78	78	97	100	115	143	143	143	160	160
L1	in mm	36	36	50	50	50	80	80	80	80	80
M	in mm	5,5	5,5	10,5	10,5	12,5	12,5	12,5	12,5	15	15
N	in mm	11	11	21	21	25	25	25	25	30	30
G in DIN 912		M5	M5	M6	M6	M8	M8	M8	M8	M10	M10
Amount of screws		1	1	1	1	1	1	1	1	1	1
Max. fastening screw	in Nm	8,45	8,45	14,5	14,5	35	35	35	35	70	70
Installation wrench		DIN911									

SIK - Datasheet

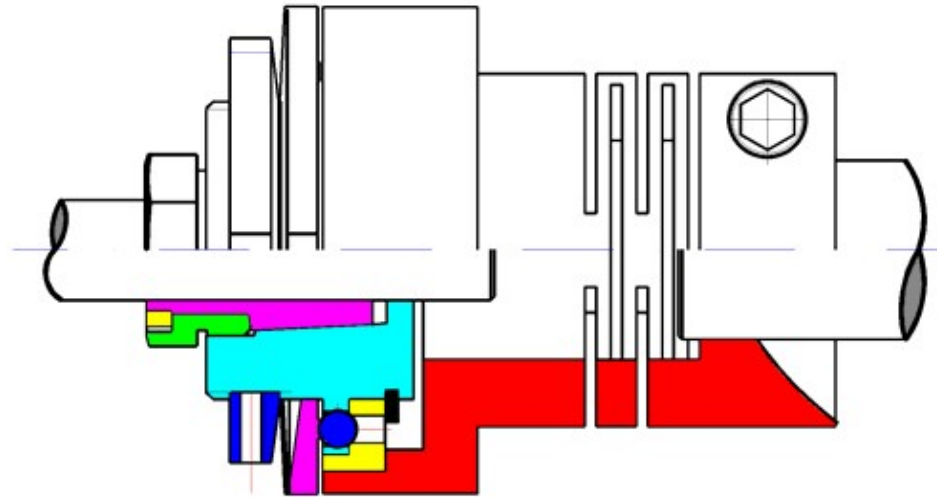

Torque-Limiter-Coupling - SIK

		Technical Data									
Size SIK		005	010	020	035	050	070	115	170	300	600
Size ASK		040	040	050	050	060	080	080	080	100	100
Disengagement torque	in Nm	2,5-5	5-10	10-20	18-35	25-50	35-70	55-115	80-170	150-300	300-600
Mass (ca.)	in Kg	0,6	0,6	0,9	1,8	1,8	3,1	3,1	3,1	7,1	7,1
Moment of inertia	10^{-6} kgm ²	0,3	0,3	0,6	1,3	1,3	3,8	3,8	6,1	16,6	16,6
Material:		SIK Coupling: Stahl					ASK fitting: Al-alloy (steel fitting on request)				